

WR4 外形图

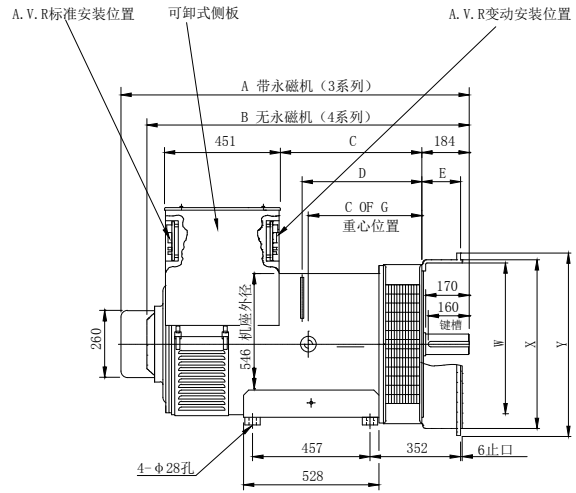

4片盘式联轴器, 总厚4.8mm
 螺母紧固螺栓须用48kgf.m
 或479N.m力矩拧紧

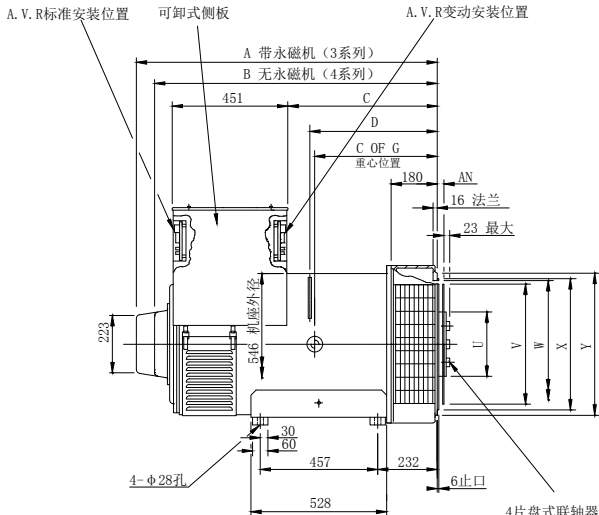
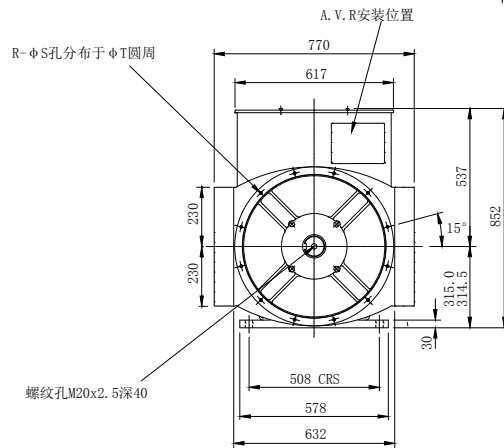
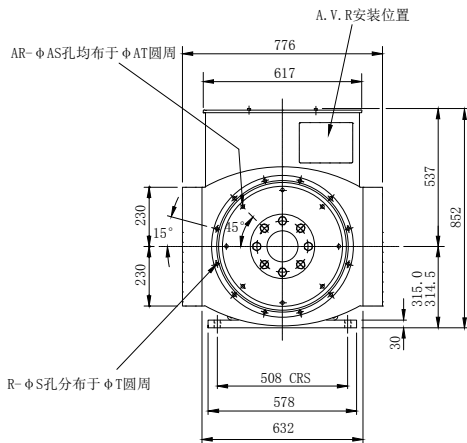
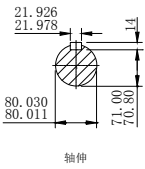

● 单支点

		尺 寸				
		A	B	C	D	C of G
SAEI	WR444C	1172	1101	584	493	463
	WR444D	1172	1101	584	493	483
	WR444E	1172	1101	584	493	504
	WR444F	1262	1191	674	583	530

盘片式联轴器						
S. A. E. No	AN	AR	AS	AT	U	V
11.5	39.68	8	10.3	333.4	250	352.3
14	25.4	8	13.5	438.1	250	466.6
18	15.87	6	16.7	543.0	250	571.1

法兰式过渡节套						
S. A. E. No	R	S	T	W	X	Y
0	12	14	679.5	626	647.6	711
1/2	12	14	619.1	569	584.1	680
1	12	12.7	530.2	496	511.1	617
2	12	11	466.7	432	447.6	617
3	12	11	428.6	394	409.5	617

运输数据		
	净重 (kg)	毛重 (kg)
WR444C	850	910
WR444D	915	975

● 双支点

		尺 寸				
		A	B	C	D	C of G
SAEI	WR444C	1326	1255	554	463	433
	WR444D	1326	1255	554	463	453
	WR444E	1326	1255	554	463	474
	WR444F	1416	1345	644	553	500

法兰式过渡节套							
S. A. E. No	R	S	T	W	X	Y	E
0	16	14	679.5	632	647.6	711	150
1/2	12	14	619.1	569	584.1	648	150
1	12	12.7	530.2	496	511.1	553	150
12V135	12	14	625.0	590	604.9	660	158

运输数据		
	净重 (kg)	毛重 (kg)
WR444C	850	910
WR444D	915	975
WR444E	995	1055
WR444F	1100	1160